

# 602

ELECTRIC  
MOTORCYCLE

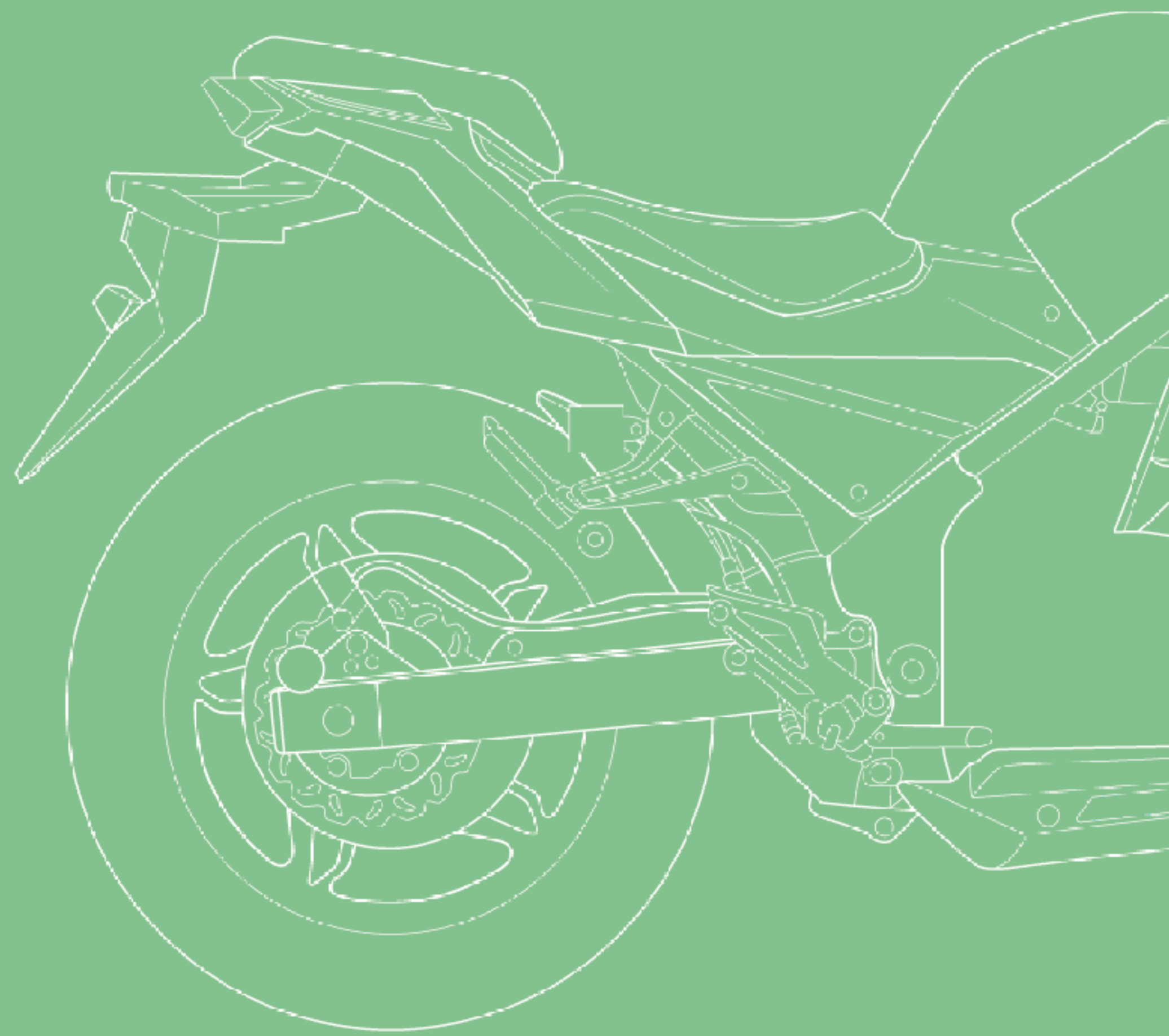





## Thank you for purchasing your DEVS Type 602.

*These operating instructions correspond to the date of printing and are the latest version of the series. It is not possible to exclude minor deviations that arise from further design developments.*

*All data contained herein are non-binding. DEVS reserves the right in particular to change technical specifications, prices, colors, types, materials, services and service services, design, equipment and other, without notice and without giving any reason is free to remove, replace the local conditions as well as stop the production of a particular model without prior notice. It does not guarantee delivery, differences in illustrations and descriptions, or misprints and mistakes. No part of this publication may be reproduced without the relevant prior written permission. The illustrations used in this use and maintenance manual may not exactly match your vehicle.*

***This manual and the original delivery protocol must stay with the vehicle at all times. If you choose to sell your 602, please pass it to the new owner.***



# INDEX

## OF CONTENTS

Foreword	2
Safety warnings	4
Component locations	5
Instrumentation	6
Key lock and alarm	7
Controls	8
Charging the battery	9
Battery safety	10
Pre-driving inspection	12
Riding tips	14
Range	17
Inspection and maintenance	18
Troubleshooting	20
Error codes	21
Tech data	22
General notes	25
Guarantee policy	28





## SAFETY WARNINGS

Read this user manual carefully before riding this motorcycle!

For the safe handling of the motorcycle, observe these safety instructions in the operating instructions and carefully read this manual.

The motorcycle is designed and homologated to the highest standards for road traffic. It is not designed for field use or racing. Please pay attention to the warning labels when touching or disconnecting elements. They are seen for example on the battery charger, battery box and other high voltage areas.

It is forbidden to remove any equipment or parts of the motorcycle. Any manipulation of the wiring of the motorcycle outside an authorized service center is prohibited. It is forbidden to use the motorcycle in an unattended condition. It is forbidden to replace parts of the motorcycle with parts not approved by the manufacturer.

Do not operate the motorcycle under the influence of alcohol, drugs or medication. Do not operate the motorcycle when you are not physically fit and able. Be highly visible at all times. Follow the road rules.

The motorcycle is designed to carry you and one passenger. When you carry a load or passenger it can affect the stability and handling. Always ride at reduced speeds and observe the limits when carrying loads.

Wear protective clothing, such as a helmet, gloves, suitable boots, trousers and protectors with each ride. Use protective clothing that is in perfect condition and complies with legal regulations.

For some operations, special tools need to be used. If you do not have these tools, contact an authorized service center. Components that cannot be reused after disassembly must always be replaced by new ones. Some screws require gluing, follow the manufacturer's instructions when working with them. Components that will be reused should be carefully checked and cleaned. After the service, you need to make sure the motorcycle is in perfect condition.

The standard warranty guarantee is covered by the terms and conditions. It will be voided by damage caused by actions contrary to these operating instructions.

For your safety, use only the spare parts supplied by DEVS. Damage arising from the use of third-party products is not a responsibility of DEVS. Removing or modifying your lights other equipment can also make your motorcycle illegal.



# 602

## COMPONENT LOCATION

1. Headlight
2. Front direction indicators
3. Front brake
4. Instruments
5. Side reflectors
6. Stand
7. Rider's main seat
8. Battery
9. Rider's main foot pegs
10. Rear position and brake light
11. Rear direction indicators
12. Rear reflector
13. Rear brake
14. Rear adjustable suspension
15. Passenger seat
16. Main 200A breaker fuse
17. VIN plate
18. Passenger grab handle

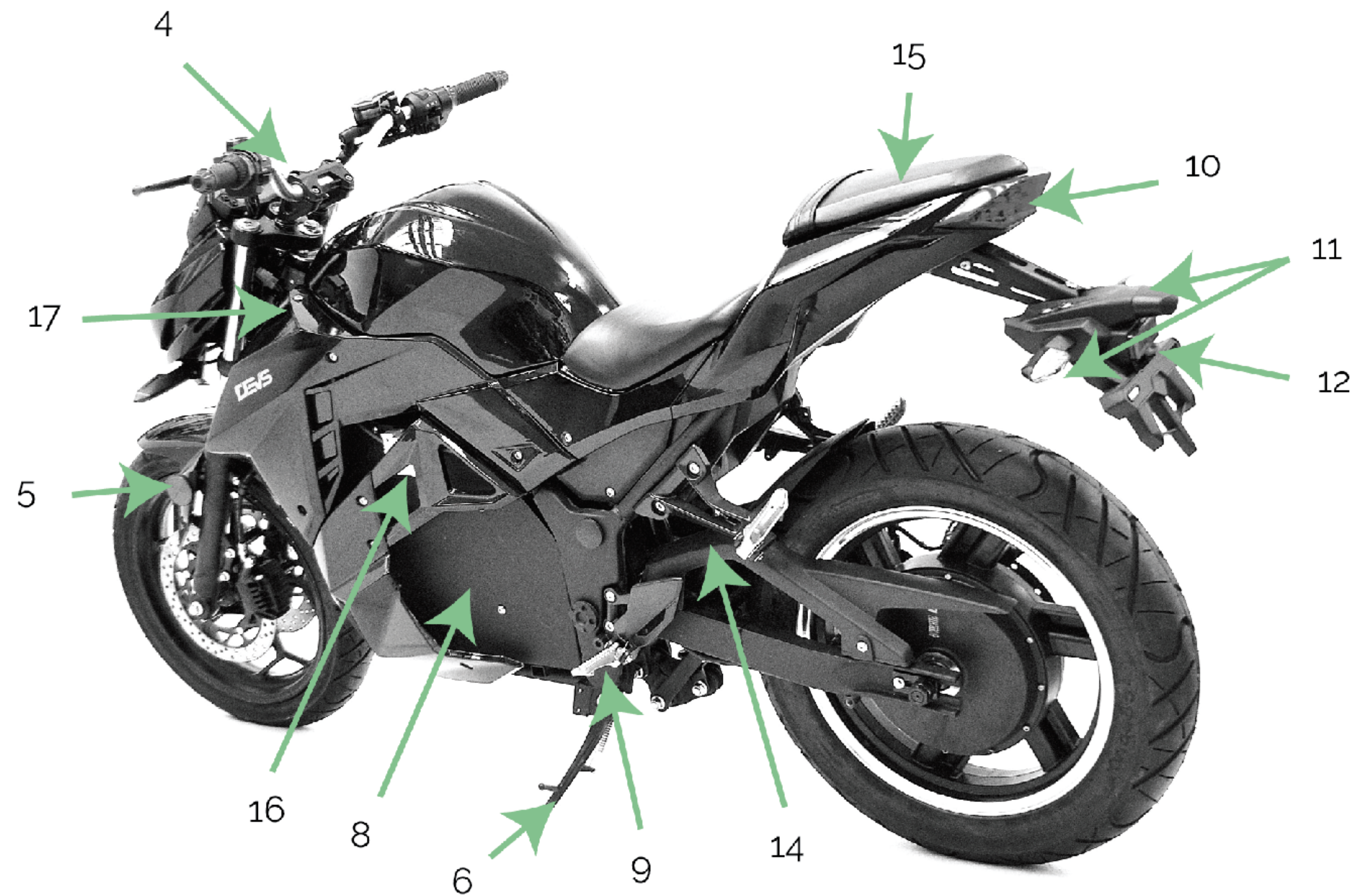
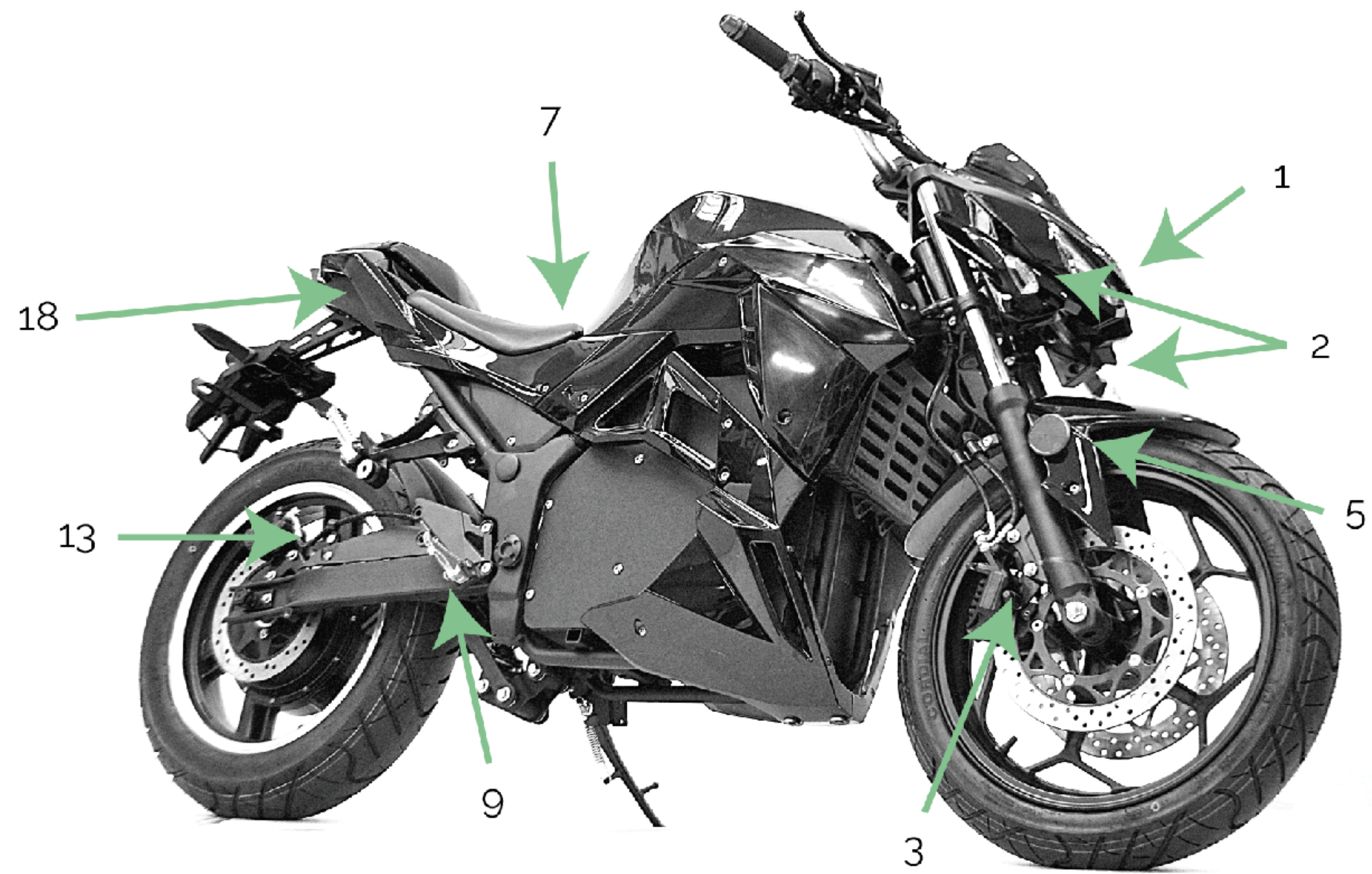



# 602

## INSTRUMENTATION

1. Air temperature. Use as a reference for the operation of the battery within the stated safe range.
2. Quick reference indicator of battery charge level.
3. Actual battery voltage. Use as an accurate reference for the remaining capacity of the battery.
4. Trip timer.
5. Total kilometers (displayed for 5 seconds after switch on), and subsequently trip kilometers.
6. Speed in kilometers per hour. Use as a reference to the stated road speed limits.
7. Mode selected (currently not used).
8. Warning lights for indicators.
9. Warning lights for high beam.





# 602

## KEY, LOCK AND ALARM

This switch controls the ignition and locks the steering. The various positions are described as below.

1. OFF position. All electric system are off. The key can be removed.
2. ON position. Used for operating the motorbike. Install the key and turn clockwise. At this position the lights and dashboard will illuminate.
3. Steering lock position. With the key in the OFF position, turn the handlebars all the way to the left. Push the key down once, release and then turn the key counter-clockwise before removing. To unlock, install the key and turn clockwise.

The alarm control varies in appearance but the switches are usually defined as below.

4. Activate alarm.
5. Deactivate alarm.
6. Remote start. Press twice within 2 seconds to turn ON. Press alarm deactivate (5) to turn OFF.

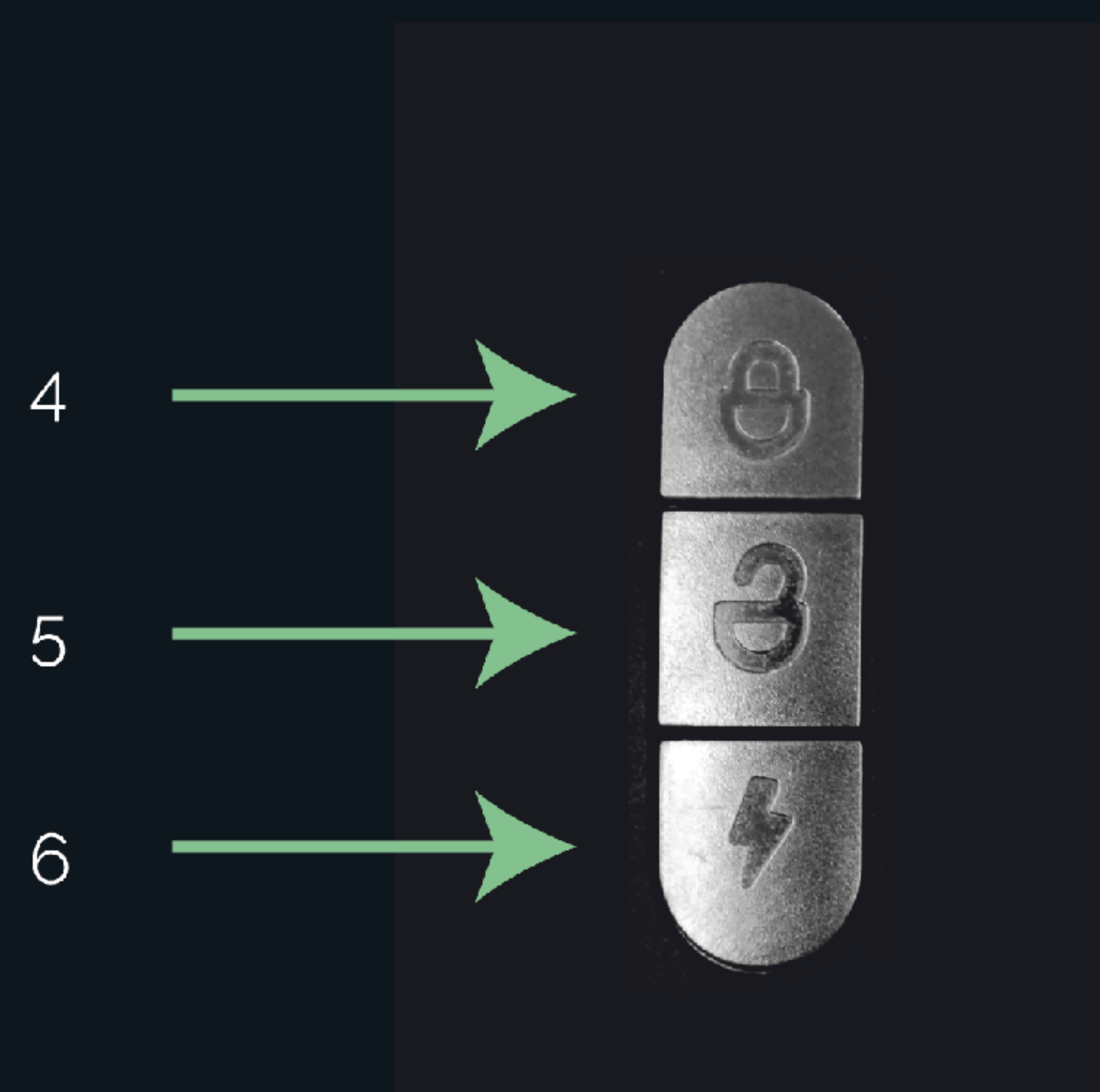
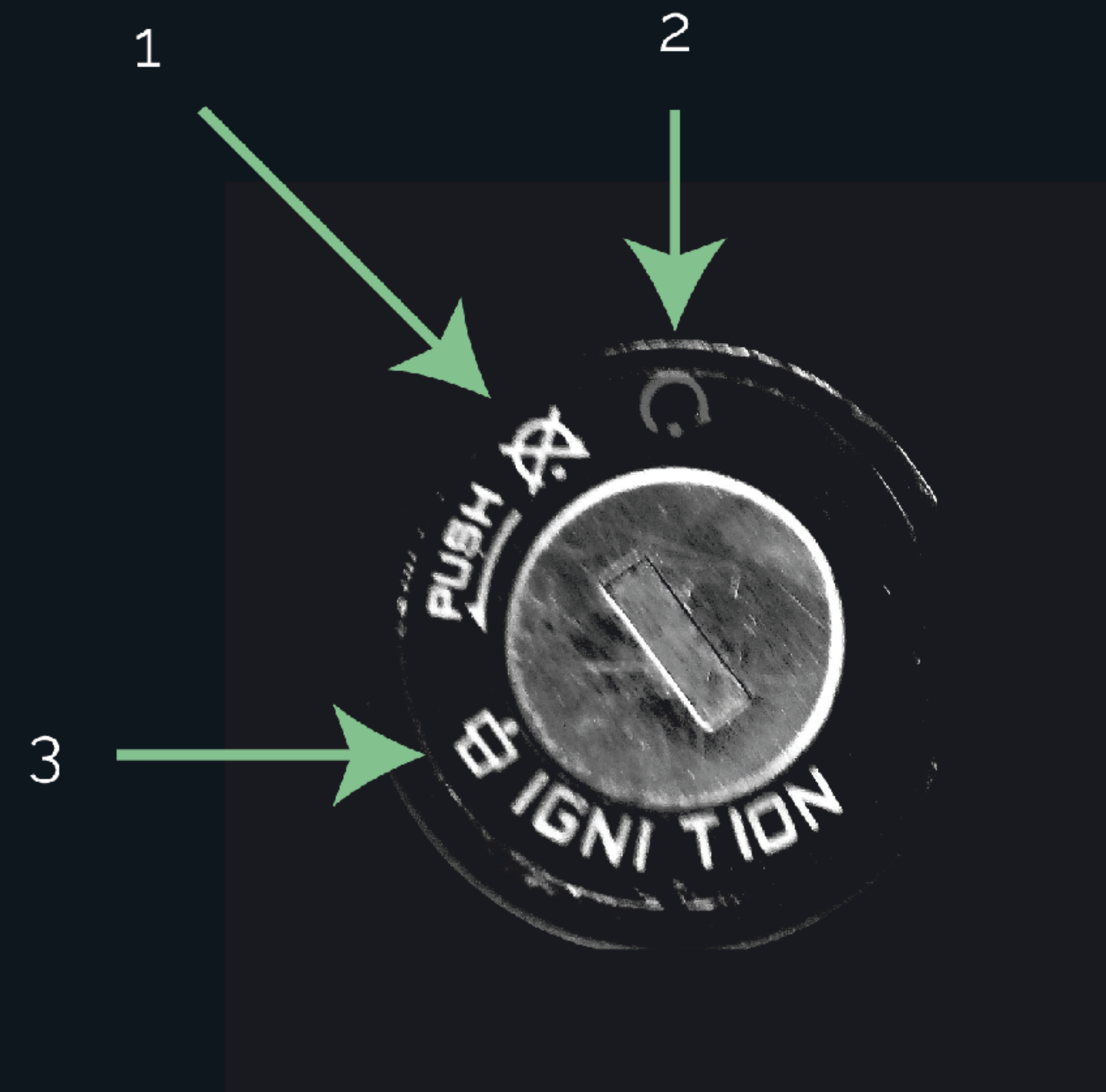



# 602

## CONTROLS

1. Left lever, operates rear brake
2. Horn switch
3. Headlight switch - dip and high beam
4. Headlight high beam flash
5. Hazard light switch
6. Indicator switch. When the switch is pressed to the left or right, the indicator will blink as appropriate. Depress to switch off.
7. Reverse momentary (red) switch. Hold in to operate in coordination with throttle.
8. Throttle. To accelerate, twist towards you. To decelerate, turn it in the opposite direction.
9. Right lever, operates front brake
10. Mode (yellow) switch. Depress to activate high-speed mode.

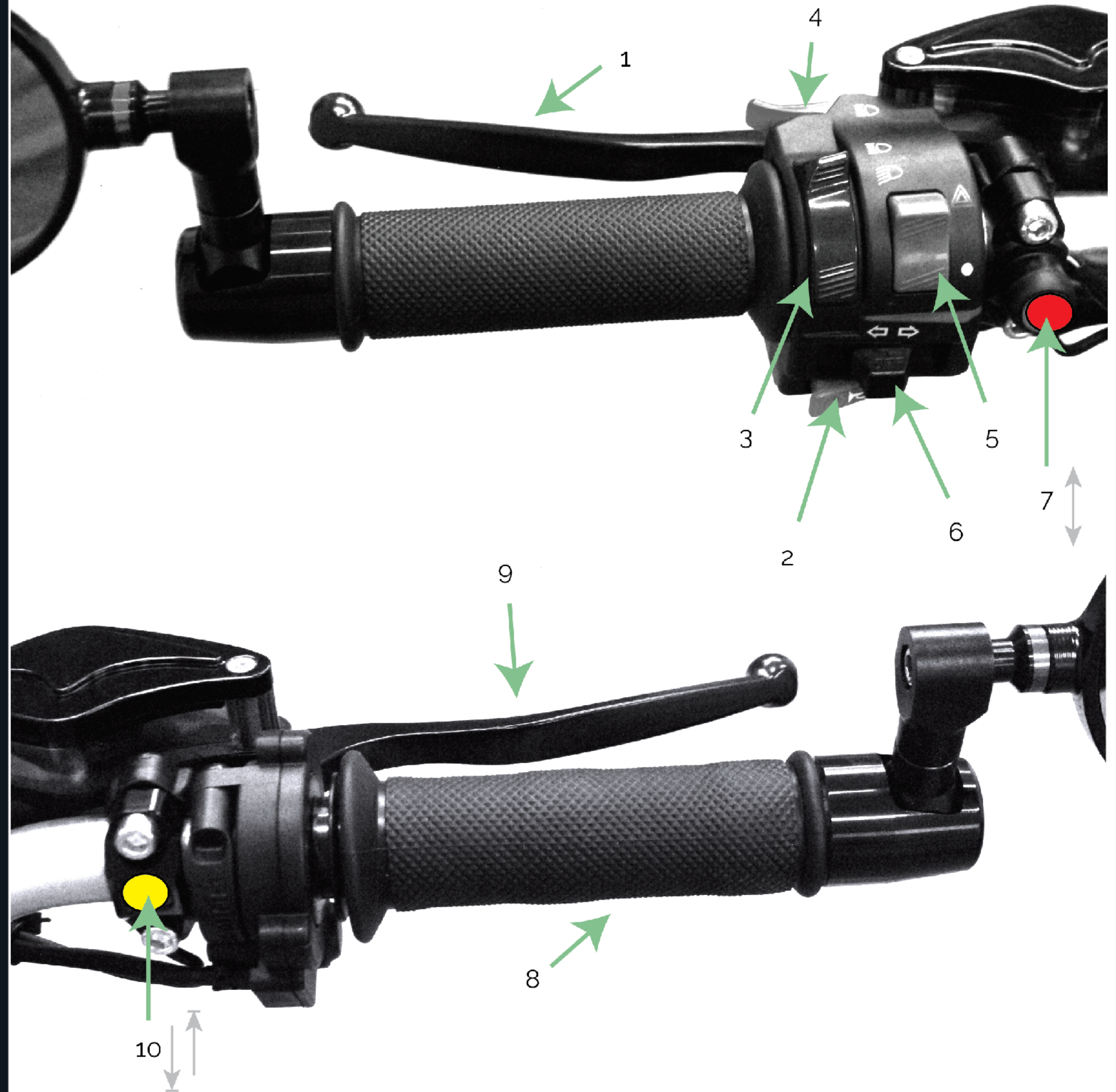



# 602

## CHARGING THE BATTERY

The charger is built-into the motorcycle and the connection is located on the right side of the body above the foot peg.

Plug the power lead into 220V local AC power supply. When the charger's lead is connected, a cooling fan will start after 5 seconds, warning that the charging process has started.

The standard 0-100% charging time, according to the time specified by the charger, is 4 hours. The ideal room temperature should be 25 ° C. In other environmental conditions, the duration of recharging may vary.

Charging is fully-automated and optimised by on-board electronics. When finished, the charger will cut off power from AC power automatically.

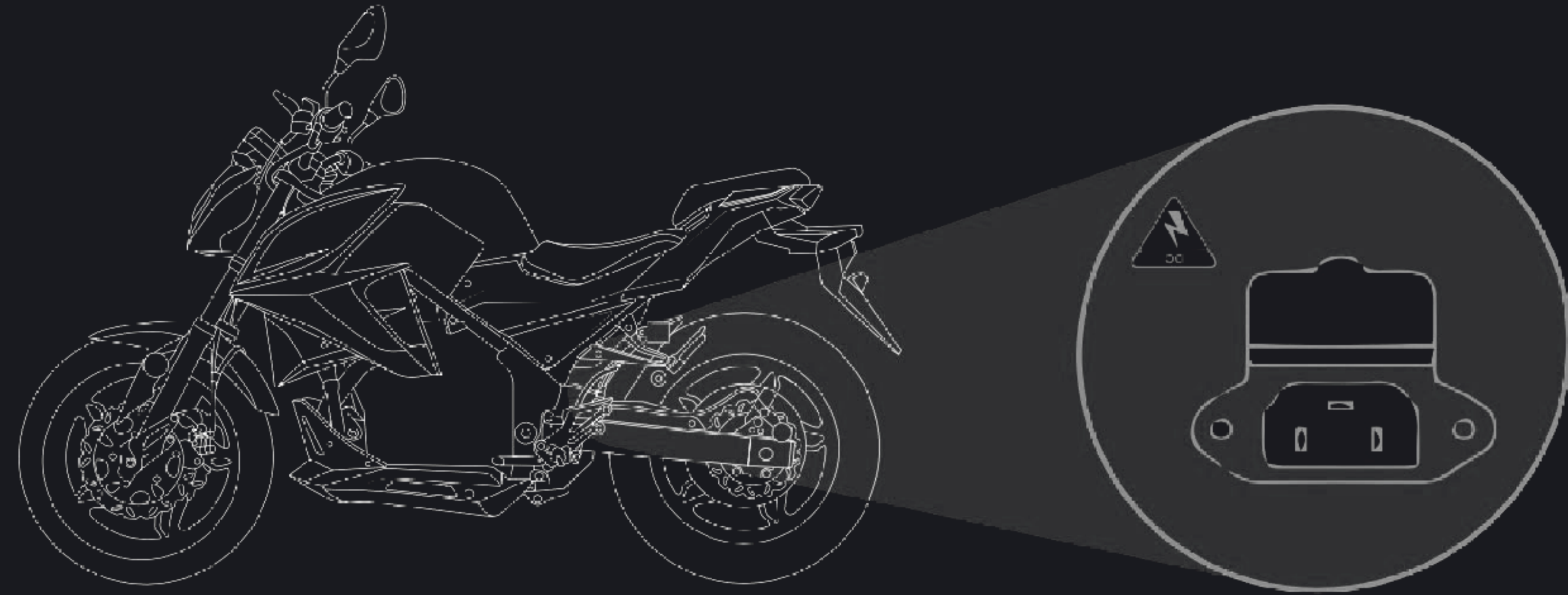

The operating range of the battery is 60V (0%) to 84V (100%) and the charging temperature range is 0C to 45C.



When recharging, put the motorcycle in a safe place that children cannot touch.



Always use a certified charger lead (UL or CE) and charge it in a dry and well ventilated environment.



Do not add electrical components to your motorcycle unless they have been approved by us.



If you are unsure of your charging equipment, contact us for assistance.



# WHEN TO CHARGE YOUR MOTORCYCLE

The optimum state to prolong the battery's life is a state of charge between 30% and 60%, which is the voltage range 67V to 75V.

Using up most of the capacity before recharging will prolong your battery's life by limiting the amount of time it spends parked at a high state of charge.

If you ride in hot weather ( $>35^{\circ}\text{C}$ ) or spend a majority of your ride at high speeds (80km/h), the power pack will benefit from allowing a few hours to cool off prior to recharging.

Never store your motorcycle at a low state of charge (below 30% SoC). Leaving the power pack at a low state of charge for a prolonged period could damage it and void your warranty.

If the power pack is fully discharged, it must be charged within 24 hours to prevent damage.





## BATTERY SAFETY WARNINGS

Observe these important points!

The lithium battery is a consumable item and the correct use method can extend its usable life to over 2000 cycles.

The motorcycle should be charged immediately after each use when the indicator indicates that the energy is less than 20%. When the battery charge is less than 20% it should not be stored, recharge it immediately.

When using the vehicle, try to avoid that the load drops to 0% (protection status), this will accelerate the degradation and shorten its useful life.

All battery cells are controlled within 0.1V in their manufacturing process. During the first 10 cycles, the battery management system (BMS) will reduce this difference down to as low as 0.05V difference. Look at 'DeltaV' on the battery APP to see this figure for your battery.

Please note, it is possible during the first 10 cycles that one cell may not be balanced and could fall below its low voltage protection level when you apply high acceleration. If this happens, the vehicle's BMS will disconnect the battery. Turning the vehicle off and back on will reset the BMS and allow the vehicle to continue. Using more gentle acceleration during the first 10 cycles is recommended to avoid this problem.

When the vehicle is stopped for a long time, store it in a cool, dry place, away from combustible materials. When stored, the lithium battery should maintain a capacity between 50% and 75% and should be checked every 30 days.

If the battery is depleted, not recharged in time, or stored with a charge below 20%, it may cause degradation and therefore loss of warranty.

Care must be taken when installing or removing lithium battery packs to avoid shocks or drops.

If you find that the battery is deformed or broken, it should be immediately discontinued and placed in an open place away from people and materials.

It is dangerous to disassemble the lithium battery. Go to an official DEVS service. Please read the instructions carefully before charging the lithium battery.

When connecting the charger, make sure the charging plug is properly connected to the charging socket and secure. During charging, make sure the lithium battery and charger are fully vented.



# 602

## PRE-DRIVING INSPECTION

1. Activate headlight, tail light and brake lights to verify operation and headlight aim.
2. Check rear seat is securely locked in place.
3. and 4. Activate indicators to test operation and warning light on instrument panel
5. and 6. Inspect brake lines are without leaks and brake pads have adequate depth
7. Check side reflectors not damaged
8. Verify tyres are correctly inflated, have legally required tread depth and without damage
9. Check that the battery is at 100% for the expected distance
10. Twist the throttle grip to ensure it rotates smoothly and returns normally to its starting point

**The condition of a vehicle is the owners' responsibility. The operator should check the vehicle by simple but thorough inspection to prevent the vehicle from serious consequence/accident.**

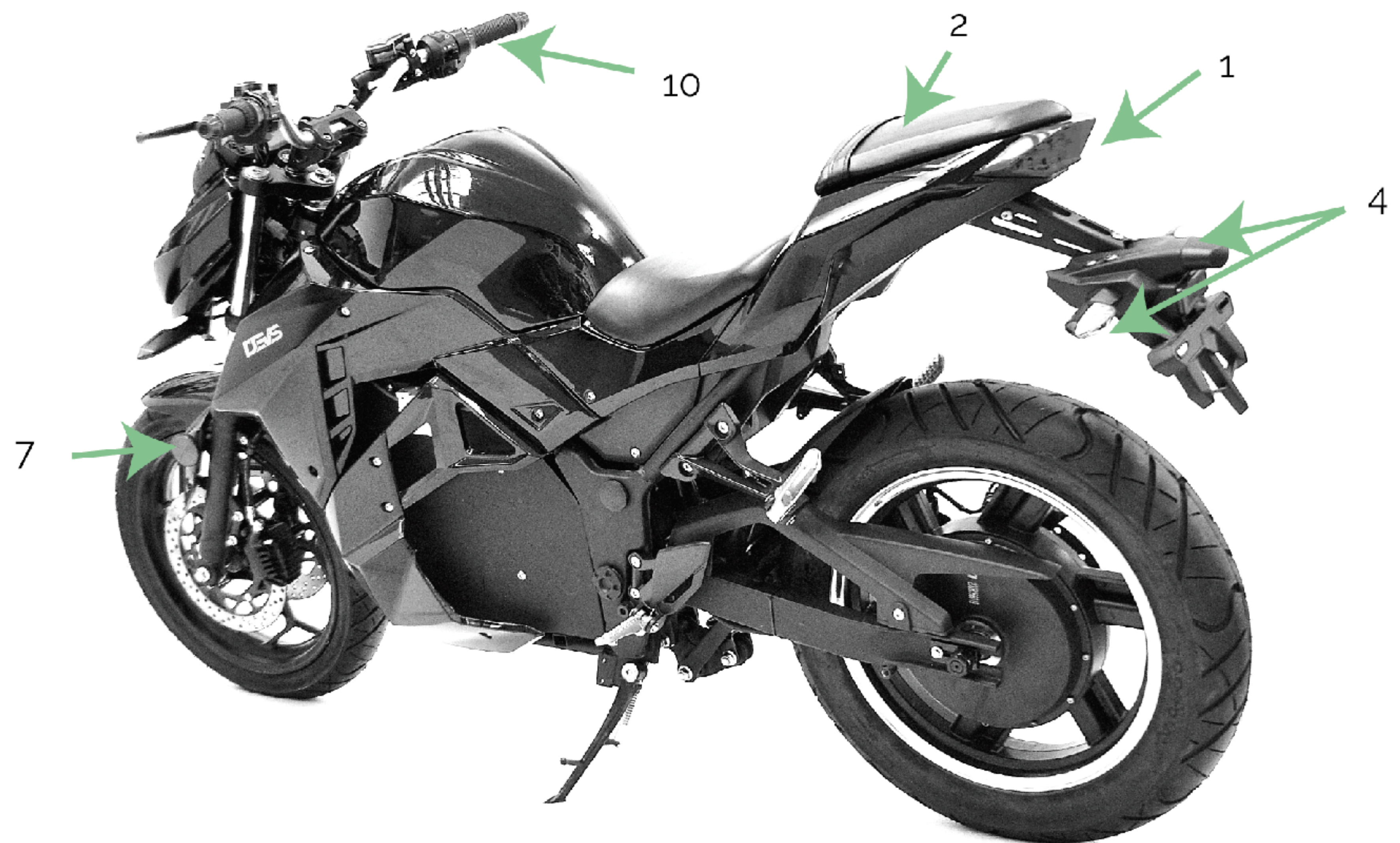
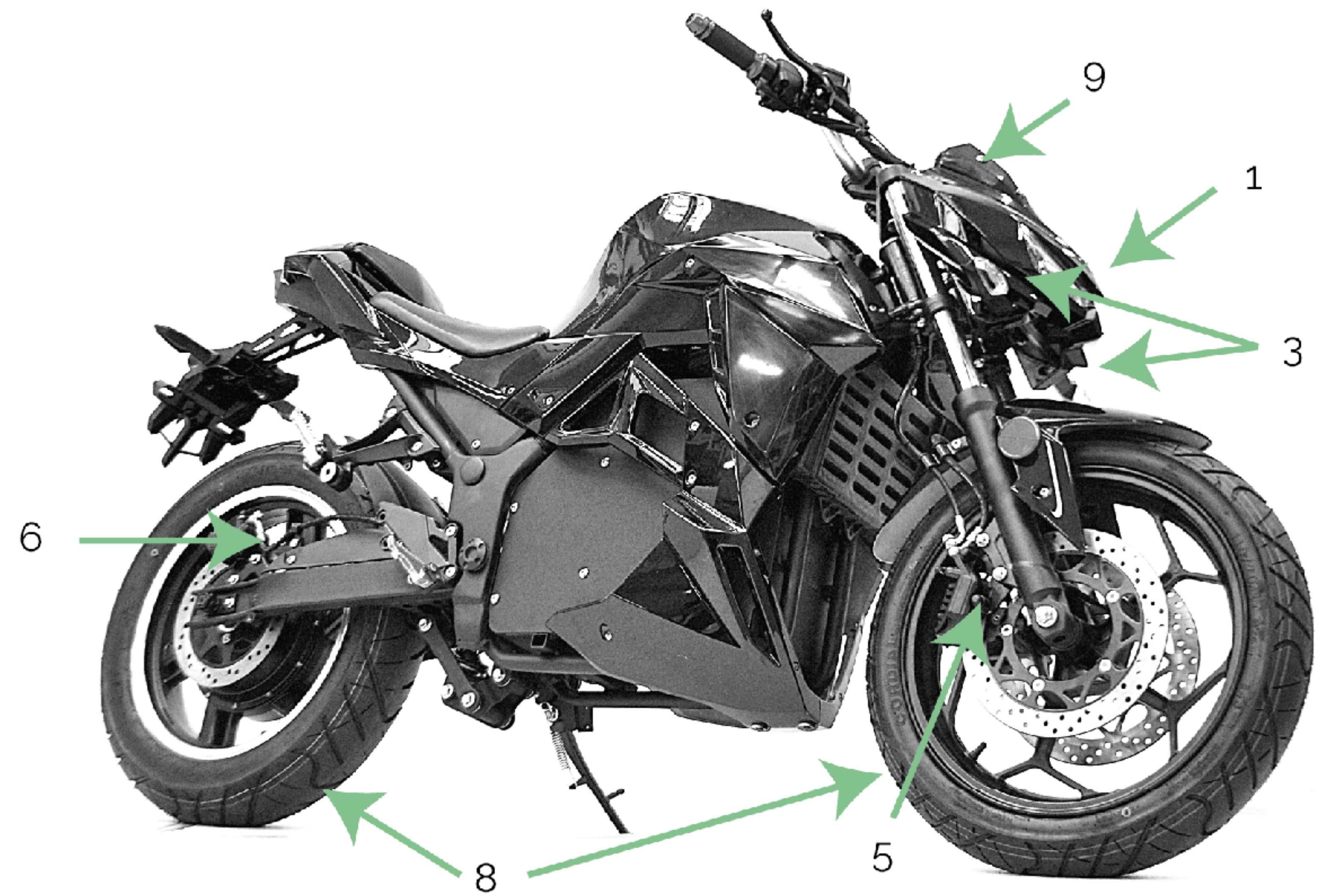





## OPERATION

Always perform the entire pre-ride checklist before riding as this can help you spot problems that could interfere with safe operation. Failure to follow this entire checklist before every ride can cause serious injury, and/or property damage to yourself and/or others.

### STARTING

- Sit on the motorcycle whilst it is still on the side stand. You may hold the handlebars to assist yourself. Set the mirrors so that you have a good view of what's happening around you.
- Activate the ignition with the key. The headlights and instrumentation will activate.
- Check the battery level is adequate for your journey.
- Select reverse if needed by holding the reverse button. Reverse gear has limited power to make it easier to control.
- Lift the side stand with your left foot.
- Check the road is clear.
- Accelerate by rotating the throttle towards you. Decelerate by rotating the throttle away from you. The throttle includes a safety spring that snaps the throttle back to end when released.
- Always ride with a helmet, firmly secured to your head.

### STOPPING

- Release the throttle to end position.
- Operate the brakes. When braking, always engage the rear brake first to retain maximum control of the scooter. Wet, oily, or sandy roads reduce braking effectiveness. Hard braking on these surfaces is dangerous.
- If the electronic brake is activated, be aware that this will initiate extra rear wheel braking that must be compensated by applying less force on the brake lever.
- After the vehicle is stopped turn off the ignition.
- Lower the side stand with your left foot while holding the motorcycle upright. This will turn the rear brake light on.
- Remove the key from the main switch.



# RIDING

## TIPS

Take your first steps of riding in a safe and spacious area, especially if you are riding a motorcycle for the first time.

Hold the handlebar firmly with both hands, never release either hand from the handlebar unless absolutely necessary.

Do not accelerate when turning the motorcycle unless absolutely necessary.

Ride at the proper speed within safe margins.

If the ground is wet or slippery, you should slow down.

Obey the rules of the road and never exceed the speed limits.



# RIDING

## TIPS

Use the motorcycle's brakes according to the road traffic conditions. Use the front and rear brake simultaneously and evenly, applying the pressure on both axles with the right and left levers.

The higher the speed, the greater the braking distance must be. Be sure to keep a safe distance between your motorcycle and other vehicles.

It is very dangerous to use only the front or rear brake, as the motorcycle may skid or lose control. You must be very careful when using the brake on wet roads and when cornering. Sudden braking on slippery or rough roads is extremely dangerous.

The motorcycle should be parked on level and firm ground. If the motorcycle needs to be parked on a slope, always point it uphill.



# CARRYING

## PASSENGERS AND CARGO

Overloading or improper loading can cause a crash in which you could be seriously hurt or killed. Observe load limits and loading guidelines in this manual.

Your motorcycle has been designed to carry you and only one passenger. When you carry a passenger or cargo, you may feel some difference during acceleration and braking.

Even if your motorcycle is properly loaded, you should ride at reduced speeds while carrying cargo.

If you change your normal load, you may need to adjust the suspension.

Distribute cargo weight evenly on both sides. We recommend using saddle bags or a top trunk. Contact us for the complete range of approved accessories.



# 602

## ELECTRIC MOTORCYCLE RANGE

The range performance of an electric motorcycle is different from petrol-engine driven or human-powered vehicles. It's very important to understand how the electric 601 works before riding.

The range is largely influenced by the driver's weight and the additional load, weather conditions, road conditions, the way it's driven, the number of starts (e.g. on crossings), the condition of tyres (especially their inflation) and battery wear and tear.

In extreme conditions, the range can be reduced to less than 50% of the indicated value.

### IDEAL CONDITIONS

Flat terrain, constant speed, no full load, no head-wind, correct tire pressure, driver weight < 70kg, no payload, approx. 20°C ambient temperature.

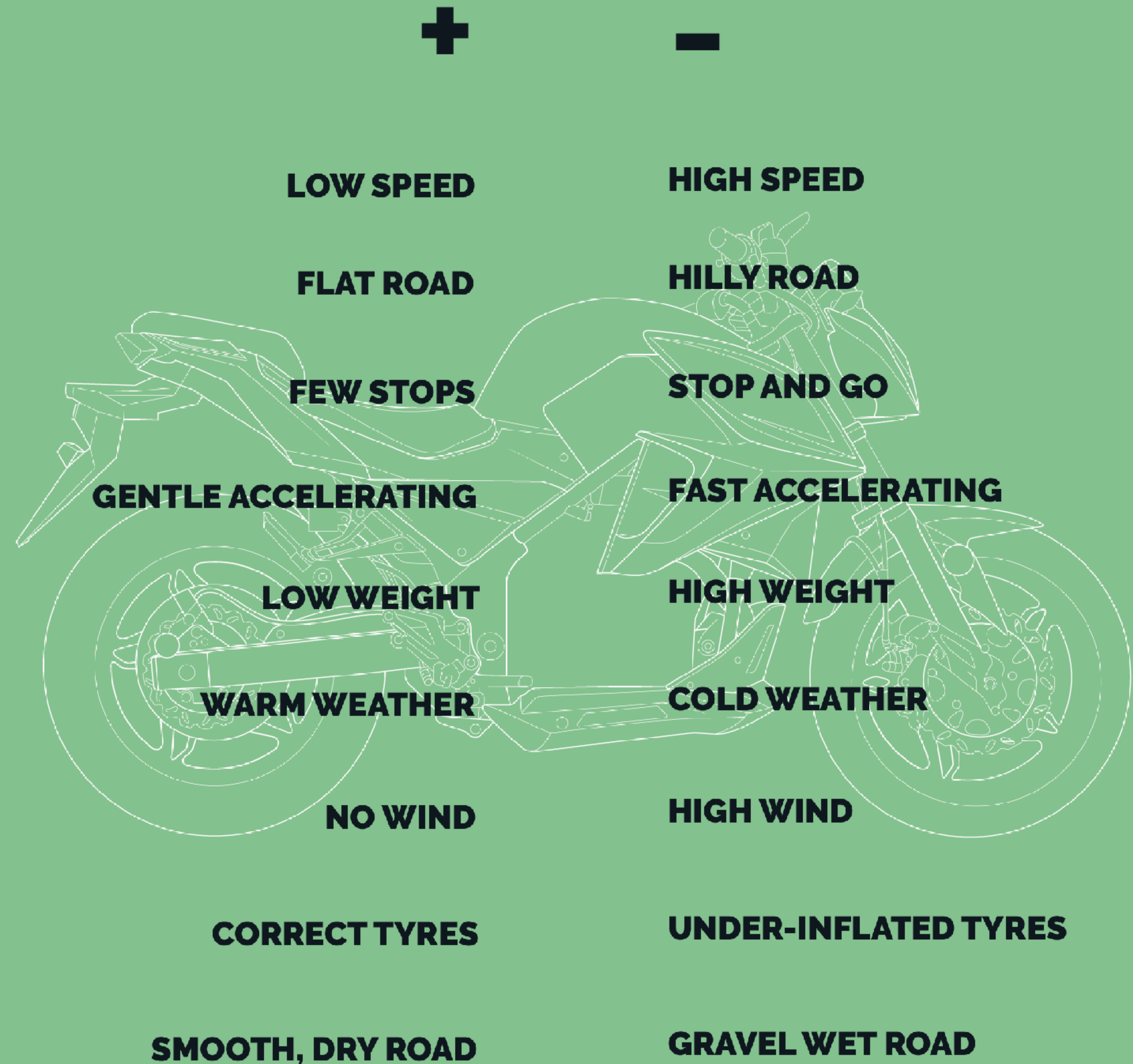



# 602

## INSPECTION, MAINTENANCE AND STORAGE

Regular maintenance can enhance service life and driving safety. Please refer to the inspection suggestions and take care of your e-motorcycle.

### RECOMMENDED PROFESSIONAL SERVICE

The first maintenance should be carried out one month after purchase or after the first 500Km. After the first inspection, maintenance should be carried out to our after-sales services every 12 months or 8000km. Assembly, maintenance and/or repair should only be performed by designated dealers or authorized repair centers for e-motorcycle repairs to ensure quality work

### BATTERY WINTER STORAGE

Lithium batteries should be charged to 80% capacity before winter storage. They will lose on average 9% of their charge per month. They may be safely stored at temperatures below freezing.

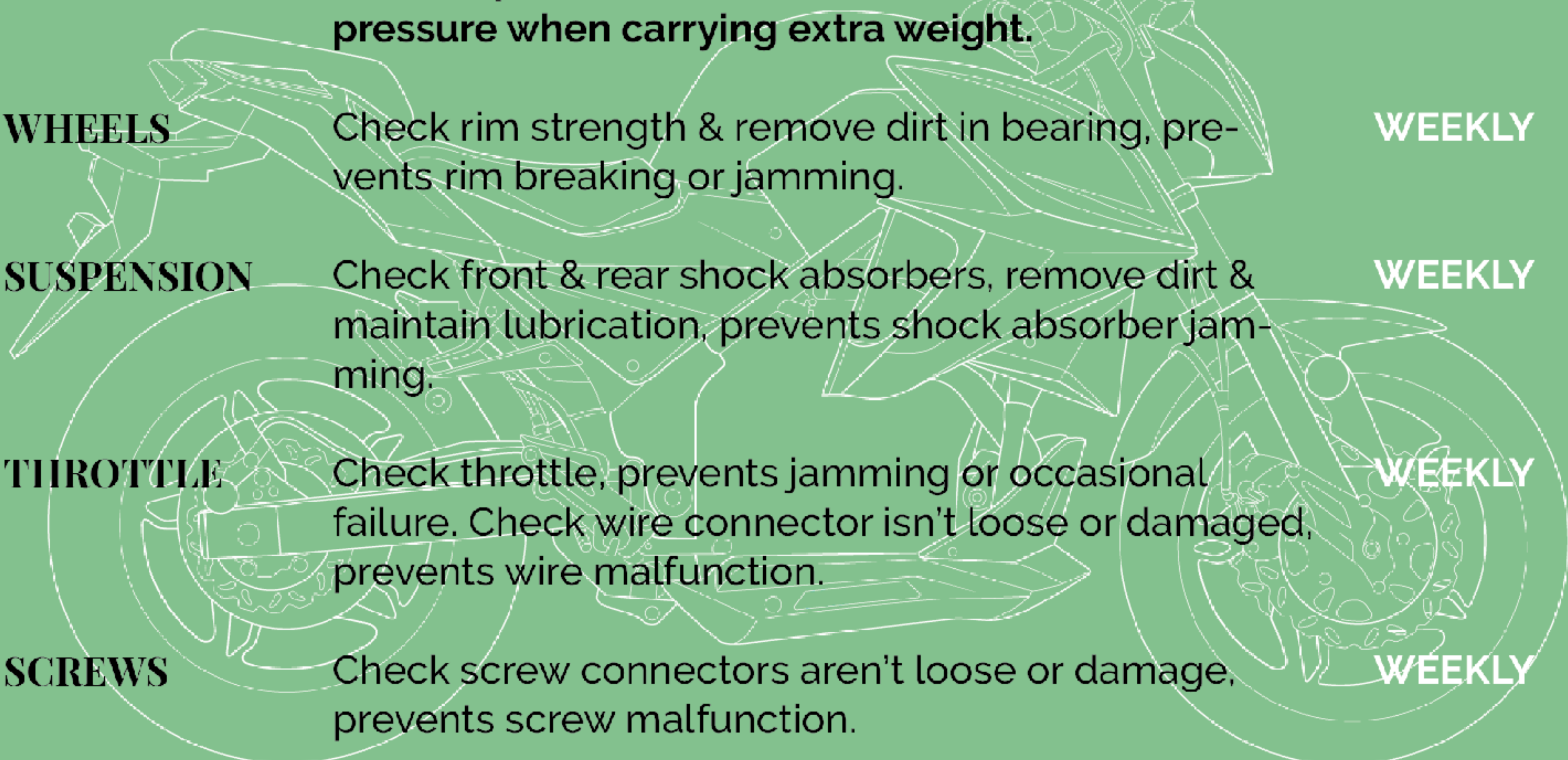

<b>BRAKES</b>	Check braking performance, inspect lines and pads for wear, prevents accidents. Check the front brake lever free play. This measurement must be between 10 - 20 mm. travel.	<b>DAILY</b>
<b>TYRES</b>	Check tyre damage & air pressure, prevents flat tyre or power over-consumption during riding. The control of tyre pressures must be carried out cold. <b>FRONT WHEEL 196 kPa (28 PSI) / REAR WHEEL 221 kPa (32 PSI). Always replace the tyres when the tread depth reaches a limit of 1.6 mm. Increase pressure when carrying extra weight.</b>	<b>DAILY</b>
<b>WHEELS</b>	Check rim strength & remove dirt in bearing, prevents rim breaking or jamming.	<b>WEEKLY</b>
<b>SUSPENSION</b>	Check front & rear shock absorbers, remove dirt & maintain lubrication, prevents shock absorber jamming.	<b>WEEKLY</b>
<b>THROTTLE</b>	Check throttle, prevents jamming or occasional failure. Check wire connector isn't loose or damaged, prevents wire malfunction.	<b>WEEKLY</b>
<b>SCREWS</b>	Check screw connectors aren't loose or damage, prevents screw malfunction.	<b>WEEKLY</b>
<b>BATTERY</b>	Check battery cell performance, prevents malfunction & lengthens lifespan. Check whether charger wire is damaged and braking and other connectors complete and reliable or not.	<b>MONTHLY</b>
<b>LUBRICATION</b>	Check wheel axles and brakes if needed to add lubrication or not.	<b>MONTHLY</b>
<b>CLEANING</b>	Surface cleaning.	<b>MONTHLY</b>





## **BRAKES**

**Read this user manual carefully before riding this motorcycle!**

**WARNING:** Brake fluid is highly toxic - keep containers sealed and out of the reach of children. If accidental consumption of fluid is suspected, seek medical attention immediately.

**WARNING:** If the fluid comes into contact with the skin or eyes, rinse immediately with plenty of water.

**WARNING:** Do not ride the motorcycle if the brake fluid is below the LOWER level mark on either reservoir. Brake fluid **MUST** be added to the reservoir before riding.

**WARNING:** If the brake lever or pedal travel is unusually long, the feel is spongy or if there is any significant loss of brake fluid contact your Motorcycle Dealer. Riding under such conditions could result in extended stopping distances or complete brake failure.

**CAUTION:** Only use new fluid from an airtight container. Fluid from open containers or fluid previously bled from the system will have absorbed moisture, which will adversely affect performance and must not be used.

**CAUTION:** Brake fluid will damage plastic or painted surfaces. Soak up any spillage with an absorbent cloth immediately and wash the area with a mixture of car soap and water.

Your motorcycle is equipped with separate front and rear hydraulic braking systems each with their own fluid reservoir. The fluid level in the reservoirs may drop slightly during normal use, as a result of brake pad wear, but should not be allowed to drop below the LOWER mark.

Your motorcycle is equipped with ABS. It is only possible to bleed the brake system manually if fluid still remains in the HCU (Hydraulic Control Unit). Bleeding a dry HCU will require an evacuation and fluid fill machine.

Brake fluid must be replaced every 12 months regardless of the distance the motorcycle has been ridden. It is recommended that this procedure is carried out by an approved garage.

**WARNING :** The rear shock absorber assembly contains highly pressurized gas.

- Do not attempt to tamper with or open the cylinder or shock.
- Do not subject the shock to high temperature or open flame.

Doing either of the above actions can cause the cylinder or shock to explode causing personal injury or death.



# 602

## TROUBLESHOOTING

Note: If there are other usage and related problems, you can check the content of the help center on the website. If you cannot solve your problem, you can contact us for consultation.

**EMAIL FOR SERVICE**  
mail@devs.bike

### **NO OPERATION**

Check the main fuse is ON and 12V/15A fuse is functional.  
Check the battery level is above the 60V cutoff.  
Check temperature is in operational range -20C to 60C.

### **NO CHARGING**

Check the connections are secure.  
Check that the battery isn't already full.  
Check the external temperature is in the allowable range of 0C to 45C.  
Use the APP to check that the BMS is active.

### **SYSTEMS ARE ON BUT MOTOR IS NOT WORKING**

Check that the brake is not engaged, which disables the throttle when the yellow switch is turned on.  
Check the throttle wiring is intact.  
Roll the bike forward and backwards and try again to move.  
If a 'beep' is heard, check the error code against the list on the next page.

### **THE SUSPENSION IS UNCOMFORTABLE**

Loosen the locknut and adjust the spring tension down to firm or up to soften.  
Check you are not over the allowable weight (155 kg)

### **12V ACCESSORIES NOT WORKING (LIGHTS, HORN ETC)**

Check the 12V/15A system fuse under the rear seat and replace if necessary (blade fuse).  
Check wiring connections are secure.  
Remove accessory and verify operation from external 12V source.

### **THE BIKE MAKES A RATTLING NOISE**

Some such noise is possible on all motorbike, but it is more obvious because an electric motorbike is otherwise quiet. Assess if the noise shows some part has come loose.

### **THE RANGE IS SHORTER THAN EXPECTED**

Follow the tips for riding to maximise range. Some decline of approximately 20-40% is expected over a period of 5 years' of average use.





## ERROR CODES

When an error occurs, a buzzer will send out information.

When the motorcycle is turned on normally, the buzzer will sound once and then stop.

If there is a long beep, please check whether the brake and throttle are effective at the same time.

**If there are 1 to 15 beeps, judge the fault based on the number of sounds.** The fault table is as follows:

1 - Motor Hall fault. The signal wire between the controller and the motor is not connected properly.

2 - Throttle failure. The throttle does not return to zero, or the throttle is broken. Note that the fault will be displayed by default when the controller is restarted, and the fault will disappear after the self-check is passed.

3 - Current protection restart.

4 - Phase current overcurrent.

5 - Voltage failure. The voltage is too low or too high, which exceeds the allowable range of the controller.

6 - Anti-theft alarm signal.

7 - Motor over temperature. Motor temperature is too low or too high beyond the scope of use.

8 - Controller over temperature. The temperature of the controller is too low or too high beyond the use range.

9 - Phase current overflow.

10 - Phase current zero point fault.

11 - Phase line short circuit fault. The phase line is short-circuited, or the motor is faulty.

12 - Wire current zero point fault.

13 - MOSFET upper bridge fault. The upper bridge of the controller is damaged.

14 - MOSFET lower bridge fault. The lower bridge of the controller is damaged.

15 - Peak line current protection. Hardware overcurrent protection alarm.



# TECH

## DATA

Motor 5000W continuous, 8500W peak  
Maximum speed 90-100 km / h  
Climbing 35°

Battery type Lithium NMC  
Power 72V 7.2 kWh  
Autonomy average 150 km (see graph)  
Cycles >2000 times  
Charger 700-1500W  
Discharge temp. range -20 to 60C  
Charge temp. range 0 to 45C

Tyre specification:  
Front: 110/70 - 17  
Rear: 140/70 -17  
Pressure front: 196 kPa (28 psi)  
Pressure rear: 221 kPa (32 psi)  
Min. tread: 1.6mm

Net weight 119 kg (without battery)  
Maximum load <155 kg  
Total length 2035 mm  
Full width 720 mm  
Full height 1140 mm  
Seat height 800 mm  
Distance between axis 1300 mm



# 602

## BATTERY RANGE TEST RESULTS

The actual range isn't one number, it's between 50km and 250km. The stated range of 150km is an average of these figures.

Some of the factors which affect range include: speed, acceleration, number of starts and stops, ambient air temperature, and changes in elevation. The combination of these factors, as you travel from one point to another, defines your range profile. In addition, tyre pressure and payload are important considerations.

For motorcycles sold within European countries, range is calculated using European Union regulation EU 134/2014 Annex VII.

**Range vs Speed**  
(curb weight 152kg - 7.2kWh battery)

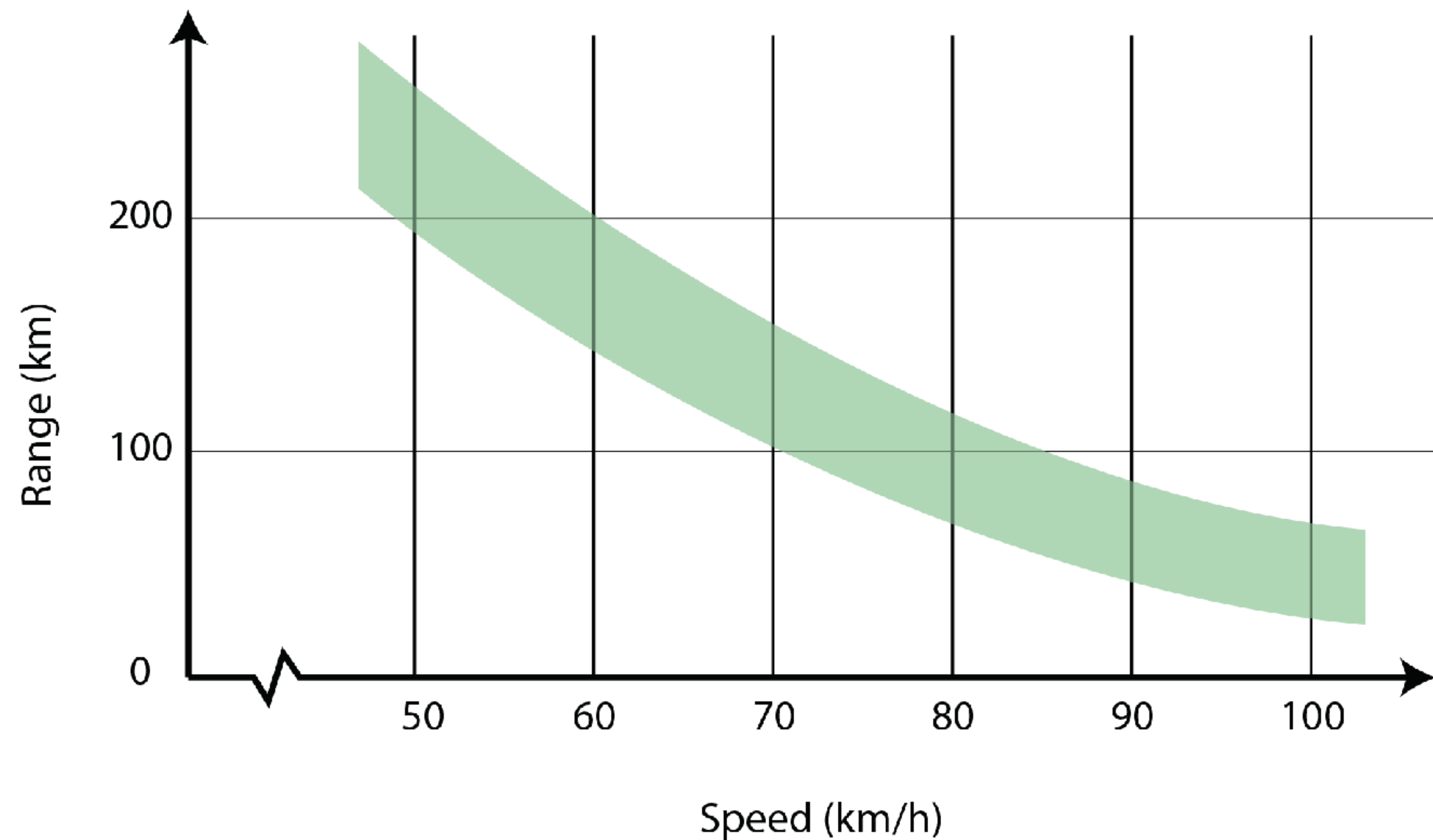



# 602

## BATTERY VOLTAGE- CAPACITY CHART

The battery state of charge follows a roughly straight line relationship to the voltage.

Fully-charged voltage is 84V, half-full voltage is 72V and low cut-off voltage is 60V.

Electronics controlling the charging and discharging of the battery ensure that the voltage is always within these upper and lower limits.

The lithium-ion batteries lose capacity based on usage cycles as well as calendar time. Aging can be accelerated by prolonged storage of the power pack at a high state of charge, especially at high temperatures.

**CAUTION:** Leaving your motorcycle unplugged between charges will maximise the long term capacity of the battery. While turned OFF, the motorcycle's electronics and self-discharge will consume about 10% of the battery's power every month.

### Voltage vs Capacity

(25C±2C to 4.20V at a constant current of 0.5C)

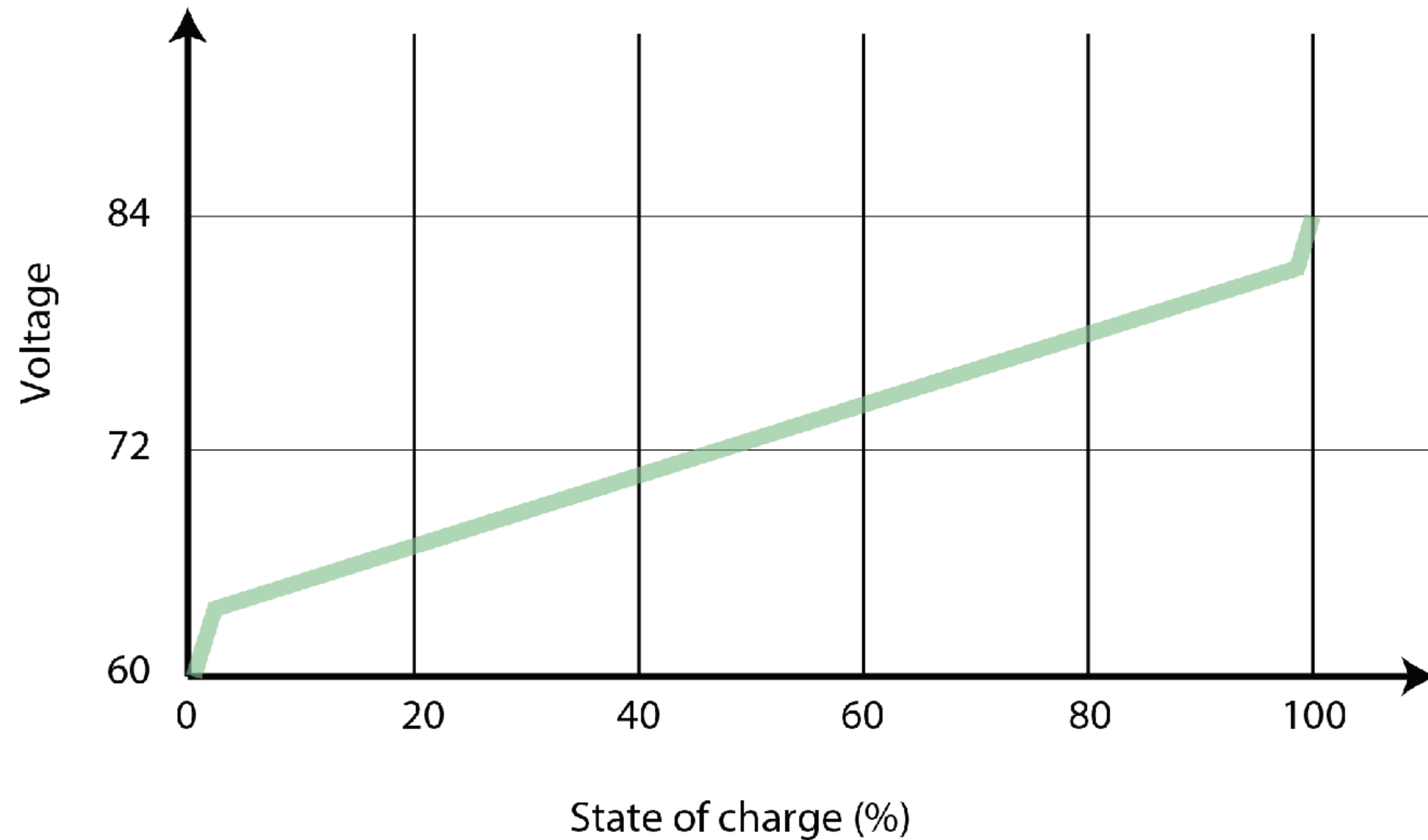



# 602

## IDENTIFICATION CODES

### **BATTERY SERIAL NUMBER**

The battery serial number is located on the top and bottom surfaces of the power pack on the right hand side of the motorcycle. The serial numbers are hidden from view, when the motorcycle is fully assembled.

### **MOTOR SERIAL NUMBER**

The motor serial number is laser etched on the right hand side of the motor housing and is visible when the motorcycle is fully assembled.

## Vehicle Identification Number (VIN)

The VIN / Chassis Number is a 17-digit code of numbers and letters stamped on the head tube of the frame. Do not alter or remove this code as it is the legal identifier for your motorcycle!

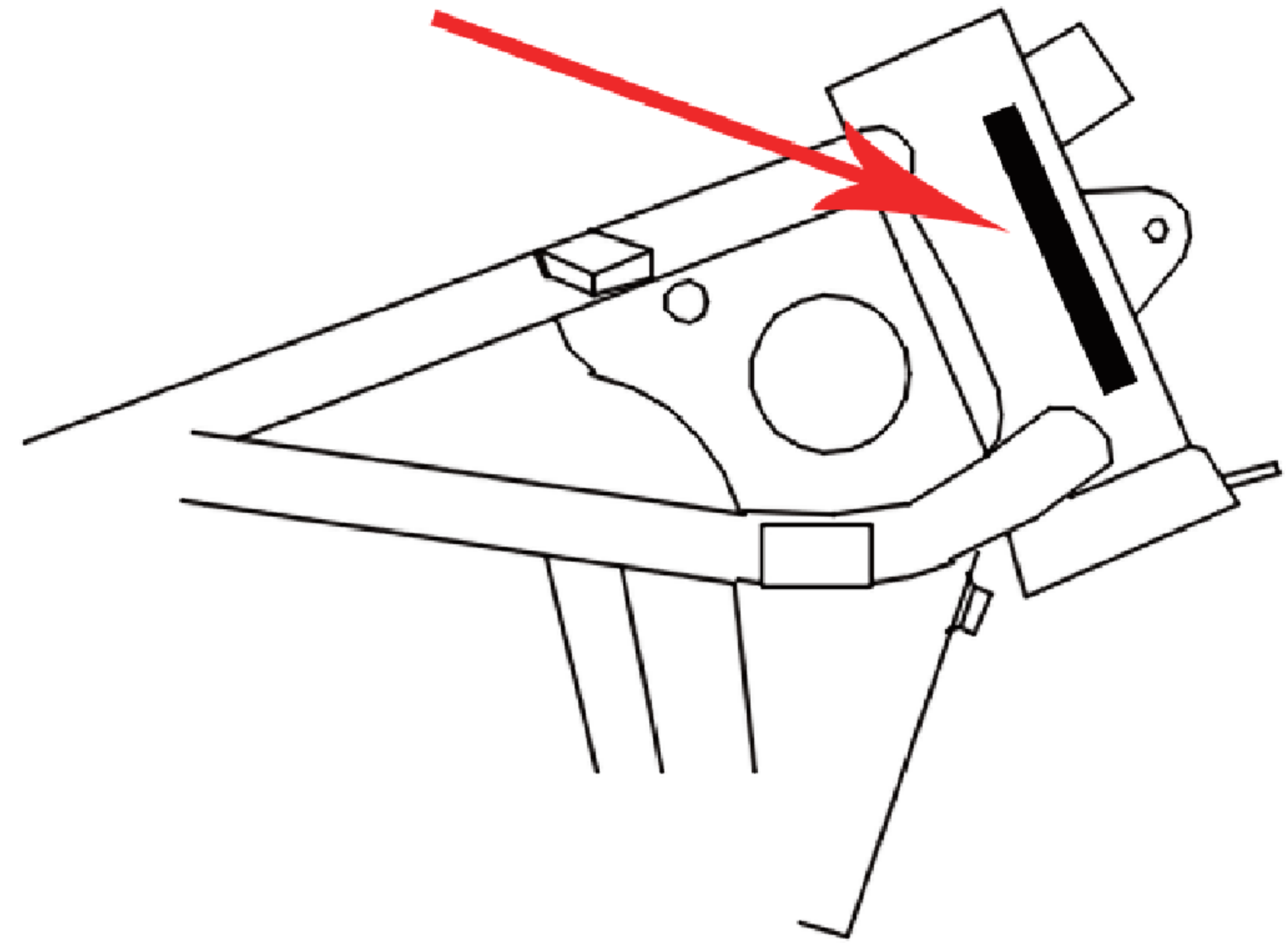





## General Maintenance

### Cleaning, Washing, Climate and Storage

To prolong the life of your motorcycle it should be washed periodically. Regular cleaning is an important factor in maintaining the value of your motorcycle.

1. Gently wash your motorcycle with a sponge or a clean soft cloth, mild detergent, and plenty of water.
2. Use care when cleaning the plastic parts (dash, fenders, and side panels), which can scratch easier than the other parts of your motorcycle.
3. Dry your motorcycle with a chamois or a soft, dry towel.

If the motorcycle is ridden after being washed, apply both brakes several times in order to remove any moisture from the brake pads.

Improper cleaning can damage electrical components, cowlings, panels, and other plastic parts. Do not use steam or high-pressure water cleaner systems; they can cause water intrusion of bearing, seals, and electrical components. Avoid spraying water of great force around the dash unit, charge port, power pack, and controller.

Do not use any harsh chemical products on plastic parts. Be sure to avoid using cloths or sponges which have been in contact with strong abrasive cleaning products, solvent or thinner, fuel (gasoline), rust removers or inhibitors, brake fluid, antifreeze or electrolyte.

Cold weather operation of the motorcycle has no permanent impact on its power pack/cells; however, the rider may see a reduction in range of up to 30%.

Note that the Battery Management System (BMS) will not allow the power pack to be discharged below  $-20^{\circ}\text{C}$  or above  $60^{\circ}\text{C}$ . When charging, the BMS will prevent the charger from charging the power pack at a temperature below  $0^{\circ}\text{C}$  or above  $45^{\circ}\text{C}$ .

Storage temperatures below  $-35^{\circ}\text{C}$  may result in accelerated permanent decay of the power pack performance, and hence it is not recommended.

Whenever you plan on not riding or storing your motorcycle for extended periods of time (more than 30 days), it is recommended that you charge the power pack to approximately 60% state of charge (SoC) and then leave the charger disconnected.

Check the SoC at least monthly and charge it back up to 60% if it has dropped below 30%.

To prolong the life of your power pack you should store your motorcycle in a cool area. The recommended storage temperature is  $-20^{\circ}\text{C}$  to  $35^{\circ}\text{C}$ .





## Electrical Maintenance

### Other important advice!

The headlight should be checked for correct alignment periodically. It must be aligned any time the suspension sag is adjusted because this affects the headlight alignment. Before the headlight can be aligned, the suspension sag and tire pressure must be correctly adjusted. The headlight can be adjusted vertically. If the vertical adjustment is off, it causes the beam to point too close to or too far ahead of the motorcycle. With the headlight on the low beam position, the motorcycle perpendicular to the ground, and the operator sitting on the motorcycle, verify the beam alignment.

The motorcycle is supplied with the headlight at a 0.5-2.5% dip.

All light assemblies are sealed and are non-serviceable. Please contact DEVS for replacement.

When excessive current flows through the high voltage motor circuit, the fusible element will melt, creating an open or incomplete circuit. This fuse must be replaced every time a circuit is overloaded.

**WARNING:** The motorcycle's high voltage system has no user serviceable parts. Disassembling, removing or replacing high voltage components, cables or connectors can cause severe burns or electric shock that may result in serious injury or death.

Your electric motorcycle is equipped with a Battery Management System (BMS) which monitors the state of the battery even when the motorcycle is turned off.

The BMS itself uses a small amount of energy, which during testing caused a reduction in the battery voltage by 1V every 17 days.

**CAUTION:** Leaving the motorcycle for a long period of time will eventually lead to the battery being completely depleted. In this situation, the BMS will also turn off to stop all loads from drawing current.

**WARNING :** Do not attempt to a fully-depleted battery, it can lead to an explosion. Contact DEVS to ask for a service repair.



## GUARANTEE POLICY

All our motorcycles are guaranteed against manufacturing defects for 24 months from the moment of delivery.

For reference, the latest applicable warranty terms are published on our website - [www.devs.bike](http://www.devs.bike).

### EXCEPTION

- All components susceptible to wear such as brake pads, tires, axles, bearings and bulbs are excluded from the warranty.
- The battery is a consumable item and subject to special terms.

### VOIDING

The warranty will be voided when any of the following cases are met:

- When a malfunction attributable to human error or negligence of the user of the machine is demonstrated.
- Meteorological causes or Acts of God.
- When the technical limit of use of the machine is breached.
- If operated in professional or commercial use.
- When non-original DEVS parts are used during repairs or when any maintenance or repair operation is carried out by a technical service not authorized by DEVS.
- All motorcycles and components have recommended maintenance periods and must be periodically checked by an official dealer. Failure to comply with these conditions invalidates the warranty against manufacturing defects.





**REGISTERED COMPANY**  
ROCKETMAN S.R.O.  
TROJANOVA 16  
PRAGUE 120 00  
CZECH REPUBLIC

**GARAGE**  
V KORYTECH 10  
STRASNICE  
PRAGUE 100 00  
CZECH REPUBLIC

